



AP4380-2000 (100Vdc max)
AP4380-2001 (200Vdc max)

Action PAK® AP4380

DC Input,
Field Configurable Isolator

Provides Isolated DC Output
in Proportion to a DC Input



- Eliminates Ground Loops
- 50% Adjustable Field Configurable Input Ranges: 10mV to 100V (200V on -2001), 1mA to 100mA
- Four Field Configurable Output Ranges: 0-5V, 0-10V, 0-1mA, 4-20mA
- Plug-in Installation
- Selectable 120/240VAC Power (9 to 30VDC Available)
- ASIC Technology for Enhanced Reliability

Description

The field configurable AP4380 isolator offers wide ranging input and output capability for scaling and transmitting analog DC signals. The AP4380-2000 will accept input voltage spans from 10mV up to 100 volts, as well as input current spans from 1mA to 100mA. The AP4380-2001 will accept input voltages up to 200V, as well as the same input current ranges. The input zero and span potentiometers enable 50% input zero and span adjustability. For example, the 0-10V input range can be elevated to 5-10V, compressed to 0-5V or set to 2.5 - 7.5V. The AP4380 offers four (4) popular output ranges: 0-5V, 0-10V, 0-1mA and 4-20mA. The 4-20mA compliance is a powerful 20VDC. Model AP4380 can be configured to accept bipolar input ranges and offers selectable normal or reverse acting operation.

The AP4380 is a 3-port industrial isolator -- the output is optically isolated from its input up to 1500 VDC. The ASIC*-based I/O channel is independently transformer isolated from the selectable 120/240VAC power supply.

Application

The Action Pak AP4380 field configurable isolator is useful in eliminating ground loops, converting signal levels and providing signal drive and redundancy. The wide ranging capability of the AP4380 provides quick universal spare part coverage.

Diagnostic LED

The AP4380 is equipped with a dual function LED signal monitor. The green, top-mounted LED indicates line power and input signal status. Active line power is indicated by an illuminated LED. If the input signal is 10% more than full scale range, the LED will flash at 8Hz. Below 0%, the flash rate is 4Hz.

Options

- U** Urethane coating of internal circuitry for protection from corrosive atmospheres.

Configuration

The factory presets the 4380-2000 input and output to 4-20mA, as shown in Figure 1. The 4380-2001 is preset to 0/200V input and 4/20mA output. The supply power is configured for 120 VAC operation. For other I/O ranges, remove the four base screws and case to access the I/O card.

Refer to Figure 1 for configuration and program the I/O channel as desired. Replace the cover before applying power.

Warning: Do not attempt to change any switch settings with power applied. Severe damage will result!

Input

1. Position input jumper "W1" for Current (I) or Voltage (V) input.

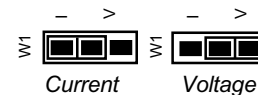

2. Set position 5 of the Input Range Selector for Unipolar (e.g. 0 to 5V) or Bipolar (e.g. -5 to 5V) operation.

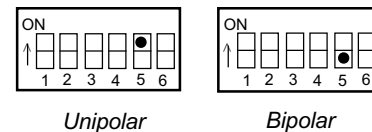

Note: A bipolar range selection will double any input range from Table 1 (e.g. 10V span becomes a -10 to 10V bipolar span)

3. Set position 6 of the Input Range Selector for Normal or Reverse operation. Reverse acting produces a decreasing output with an increasing input.

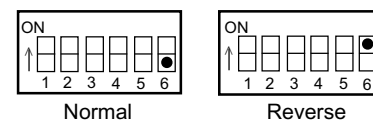

4. Using Table 1, configure positions 1 through 4 of the Input Range Selector for the desired maximum input. Round the desired maximum input value to the next highest range (e.g., 0-70V = 100V range).

Output

Warning: Do not configure the output ranges with the power on. Damage to unit may result.

1. Using Table 2, configure Output Selector for one of the four (4) standard outputs.

Power

1. Configure the AC jumpers for either 120 or 240 VAC operation. See Figure 2.

Calibration

1. Connect the input to a calibrated DC voltage or current source and apply power. Wait 1 hour for thermal stability before monitoring the voltage/current output. Refer to PIN CONNECTIONS.

2. Set the calibrator to the desired minimum input and adjust the Zero, 20-turn, potentiometer for desired minimum output.

3. Set the calibrator to the desired maximum input and adjust the Span, 20-turn, potentiometer for desired maximum output.

4. Repeat steps 2 and 3 for best accuracy.

Table 1: AP4380-2000/2001 Input Ranges

Voltage*	Current*	Input Range Selector (SW1)
20mV	2mA	
50mV	5mA	
100mV	10mA	
200mV	20mA	
500mV	50mA	
1V	100mA	
2V		
5V (-2000) 10V (-2001)		
10V (-2000) 20V (-2001)		
25V (-2000) 50V (-2001)		
50V (-2000) 100V (-2001)		
100V (-2000) 200V (-2001)		

* Use jumper (W1) to configure voltage or current input. All unipolar ranges are zero based.

Table 2: AP4380-2000 Output Ranges

Range*	Output Range Selector (SW2)
0 to 10V	
0 to 5V	
0 to 1mA	
4 to 20mA	

* For bipolar voltage outputs (e.g. -10 to +10V) see model AP4382.

I/O Card Configuration

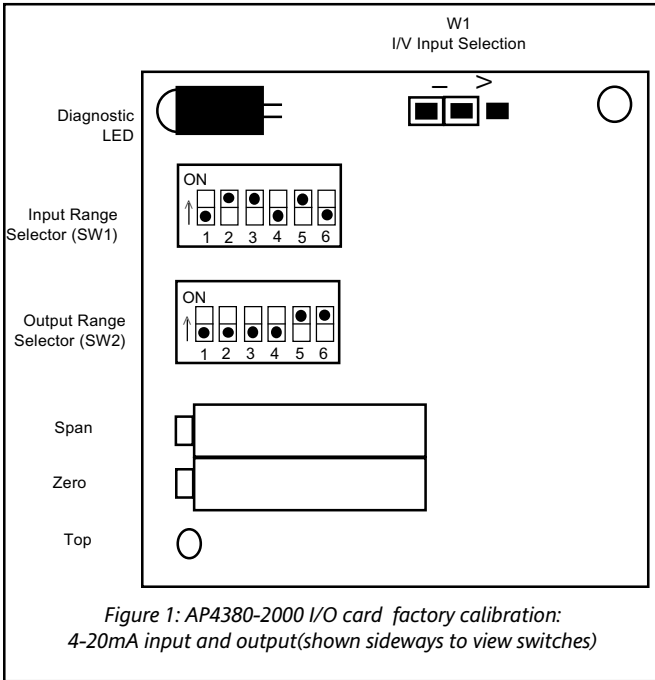

Top View Diagram

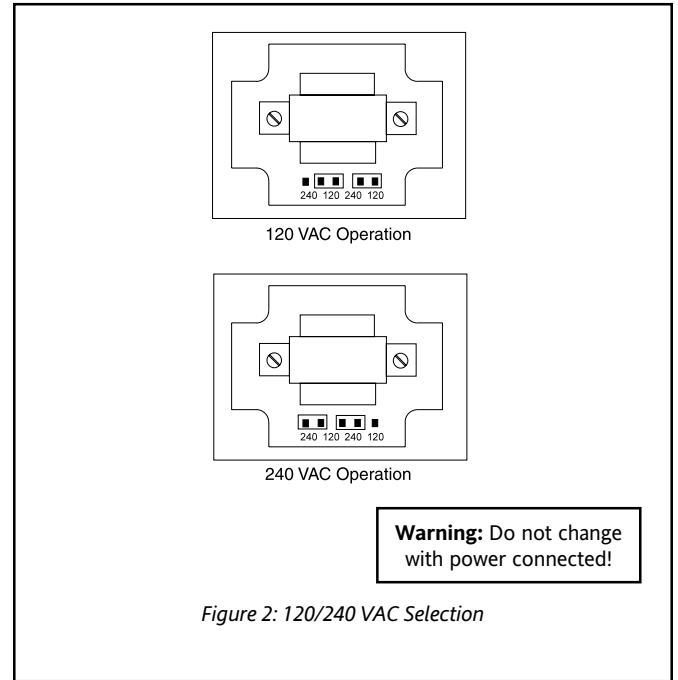

Warning: Do not configure I/O switch ranges with power on. Damage will result!

Warning: Applying voltage to the input with W1 in current (I) position will result in damage to the unit.

Mounting

All Action Paks feature plug-in installation. Model AP4380 uses an 8-pin base, either molded socket M008 or DIN socket MD08.

Dimensions

Dimensions are in millimeters (inches)

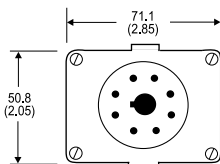
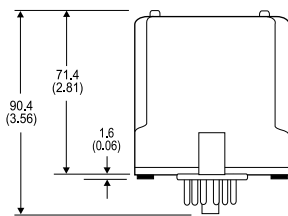

Mark II

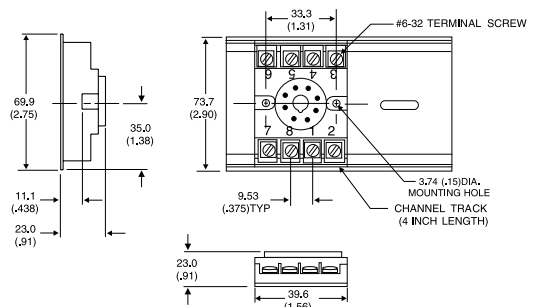

M008 (Track/Surface)

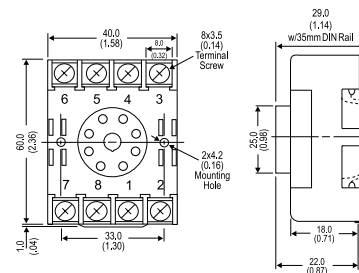

MD08 (DIN Rail)

Specifications

Input:

Voltage Input (field configurable)
Full Scale Range:
-2000: 10mV to 100V
-2001: 10mV to 200V
Impedance: >100K Ohms
Overvoltage:
Intermittent, 400Vrms
Continuous, 264 Vrms
Current Input (field configurable)
Full Scale Range: 1mA to 100mA
Impedance: 20 Ohms, typical
Overcurrent: 170mA RMS, max
Overvoltage: 60VDC
Common Mode (Input to Ground):
1500VDC, max
Zero Turn-Up:
50% of full scale range
Span Turn-Down:
50% of full scale range

Output:

Voltage Output
Output: 0-5V, 0-10V
Drive: 10mA, max (1K Ohms min. @ 10V)
Current Output
Output: 0-1mA, 4-20mA
Compliance:
0-1mA: 10V, max. (10K Ohms, max)
4-20mA: 20V, max. (1K Ohms, max)

LED Indication (green):

Input Range
>110% input: 8Hz flash
<0% input: 4Hz flash

Accuracy (Including Linearity Hysteresis):

<20mV/2mA: $\pm 0.35\%$ of full scale, typical,
0.5%, max
>20mV/2mA: $\pm 0.1\%$ of full scale, typical,
0.2%, max

Response Time (10-90%):

200 mSec., typical

Stability (Temp):

$\pm 0.025\%$ of full scale/ $^{\circ}\text{C}$, typical,
 $\pm 0.05\%$ / $^{\circ}\text{C}$, max.

Common Mode Rejection:

DC to 60Hz: 120dB

Isolation:

1500 VDC between input, output & power

ESD Susceptibility:

Meets IEC 801-2, Level 2 (4KV)

Humidity (Non-Condensing):

Operating: 15 to 95% (@ 45°C)
Soak: 90% for 24 hours (@ 45°C)

Temperature Range:

Operating: -15 to 60°C (5 to 140°F)
Storage: -25 to 70°C (-13 to 158°F)

Power:

Consumption: 3W typical, 5W max
Standard: selectable 120/240VAC, $\pm 10\%$,
50-60Hz
Optional: 9 to 30VDC, inverter isolated

Weight:

0.60lbs

Agency Approvals:

CSA certified per standard C22.2, No. M1982.
UL recognized per standard UL508.

Ordering Information

Specify:

1. Model: **AP4380-2000** or **AP4380-2001**
2. Option: U, see text
3. Line Power, see specifications
4. Factory calibration (C620): Specify input range, output range and power.
(All power supplies are transformer-isolated from internal circuitry.)

Accessories:

M801-0000 Retaining Spring
M008-A 8 pin Track Mount Socket
M004-0000 4 ft Long Channel Track
MD08-0000 8 pin DIN Mount Socket

Pin Connections

- 1 Power (Hot)
- 2 Not Internally Connected
- 3 Power (Neu)
- 4 Spare Termination
- 5 Input (+)
- 6 Input (-)
- 7 Output (+)
- 8 Output (-)

DC Power: PIN 1 = (+); PIN 3 = (-)



Eurotherm, Inc

741-F Miller Drive
Leesburg, VA 20175-8993
703-443-0000

info@eurotherm.com or www.eurotherm.com/actionio

Factory Assistance

For additional information on calibration, operation and installation contact our Technical Services Group:

703-669-1318

actionsupport@eurotherm.com

721-0545-00-P 09/06 Copyright© Eurotherm, Inc 2006